



RAMA DENTAL COLLEGE HOSPITAL & RESEARCH CENTRE

(Recognised by D.C.I. & Govt. of India, Accredited by NAAC)

RAMA UNIVERSITY UTTAR PRADESH

FACULTY FEEDBACK AND ACTION TAKEN REPORT ON CURRICULUM (2021-2022)

S.NO	FEEDBACK	ACTION TAKEN
1.	How do you rate the transformation of your students after the completion of the course	An overall development of the students is important that includes clinical as well as humanitarian on humanitarian grounds. Value added courses on intellectual development will be implemented.
2.	How do you rate the programs based on the comfort of your Students in coping with the workload	The clinical and theoretical hours will be divided depending upon the workload of the students. Mentors will be instructed to do regular meetings with their respective mentees/students and recognize the areas of problems in understanding the dental curriculum and completing their clinical workload.
3.	How do you rate the outcomes that your student has achieved from the courses	Learning outcomes are statements of the knowledge, skills and abilities individual students. Learning outcomes will be made specific, well defined, and realistic and will be framed in terms of the program instead of specific classes that the program offers. Finally the learning outcomes will also align with the program's curriculum and will made to be focus on learning products and not the learning process.
4.	How do you rate the Course Content activities that help your students in getting jobs and placements	The course content will be redefined in such a manner that includes various methods to teach advance dental skills , which will include innovations, motivational changes, and various factors which are responsible for quality dental delivery and help in facing job interviews.
5.	How do you rate the college activities that help your students in getting jobs and placements	Various CDE/Webinars/Conferences/Symposium will be organized based on -Training students on latest dentistry oriented skills, help in preparing a professional and standard CV, conducting mock interviews and MCQ based tests and establishing

Review
Principal
Rama Dental College
Hospital and Research
Centre - Kanpur

		a well planned and structured dental placement cell in the college. These all will help in better placements of the dental students.
6.	How do you rate the ambience of the college for effective delivery of the academic process	The recommendations for enhancing the educational and extracurricular ambience of the college includes- Library will be functional till late hours, promotion of indoor and outdoor games for students physical development and full time availability of teaching staff online/telephonic for solving the academic difficulties faced by the dental students
7.	How do rate the courses in terms of their relevance to the latest and/or future technologies	Enhancement in latest technologies is highly recommended. Latest dental equipments such as CBCT, Implant systems, Microscopic dentistry is highly recommended. Courses will be conducted on training the students on future advancements in dentistry at the college level.

Beevan
Principal
Rama Dental College
Hospital and Research
Centre - Kanpur



Curriculum Program Feedback Analysis [Faculty], Session : 2021-2022

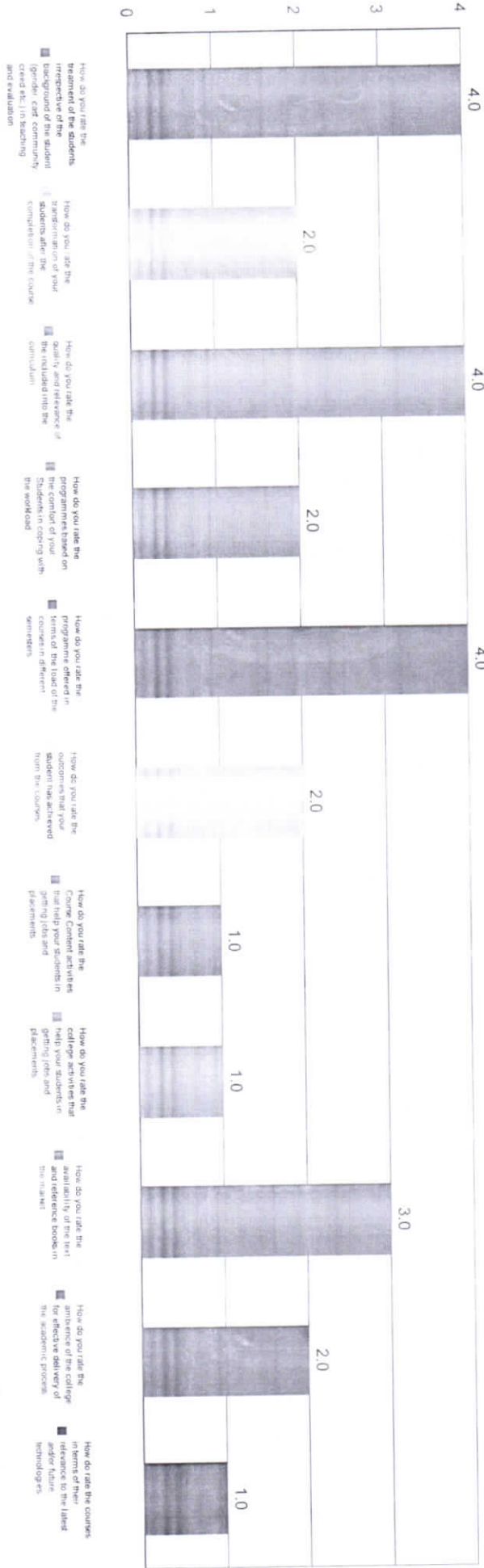

Principals
Principal
Rama Dental College
Hospital and Research
Centre - Kanpur

Department	Program	How do you rate the treatment of the students (respect to the background of the student) (gender, cast, community, creed etc.) in teaching and	How do you rate the transformation of your students after the completion of the course	How do you rate the quality and relevance of the material included into the curriculum	How do you rate the programmes based on the number of your Students in compare with the workload	How do you rate the programme offered in terms of the level of the courses in different semesters	How do you rate the outcomes that your student has achieved from the courses	How do you rate the Course Content activities that help your students in getting jobs and placements	How do you rate the college activities that help your students in getting jobs and placements	How do you rate the availability of the text and reference books in the market	How do you rate the ambience of the college for effective delivery of the academic process	How do you rate the courses in terms of their relevance to the latest and/or future technologies
BACHELOR OF DENTAL SURGERY	BACHELOR OF DENTAL SURGERY	4.0	2.0	4.0	2.0	4.0	2.0	1.0	1.0	3.0	2.0	1.0

B. U. S. S. S. S.

Principal
 Rama Dental College
 Hospital and Research
 Centre - Kanpur



RAMA UNIVERSITY UTTAR PRADESH, KANPUR ①

(vide U.P. Act No. 1 of 2014 as passed by State Legislature and recognized by UGC U/s 2(f))

Rama City, G.T. Road (Near Mandhana Railway Station)

Mandhana, Kanpur- 209217

Department of Conservative Dentistry and Endodontics

Rama Dental College, Hospital and Research Centre, Kanpur

Faculty Feedback and Action Taken Report for MDS 2021 – 2022

Feedback	Action Taken
How do you rate the quality and relevance of the included into the curriculum - Satisfactory	The curriculum has appropriate content to teach the students but with that various demonstration and programmes were held in the department.
How do you rate the ambience of the college for effective delivery of the academic process - Satisfactory	Number of journals were added in department library for the better learning of students.
How do you rate the course in terms of their relevance to the latest and/or future technologies - Unsatisfactory	Expert talks have conducted online to emphasis in the upgradation of students regarding advanced technologies.

Dr Asheesh Sawhney

Professor And HOD

Department of Conservative Dentistry and Endodontics

Dr. Asheesh Sawhney & HOD
Dept. of Conservative Dentistry
and Endodontics
R.D.C.H.R.C., Kanpur



Curriculum Program Feedback Analysis [Faculty], Session : 2021-2022

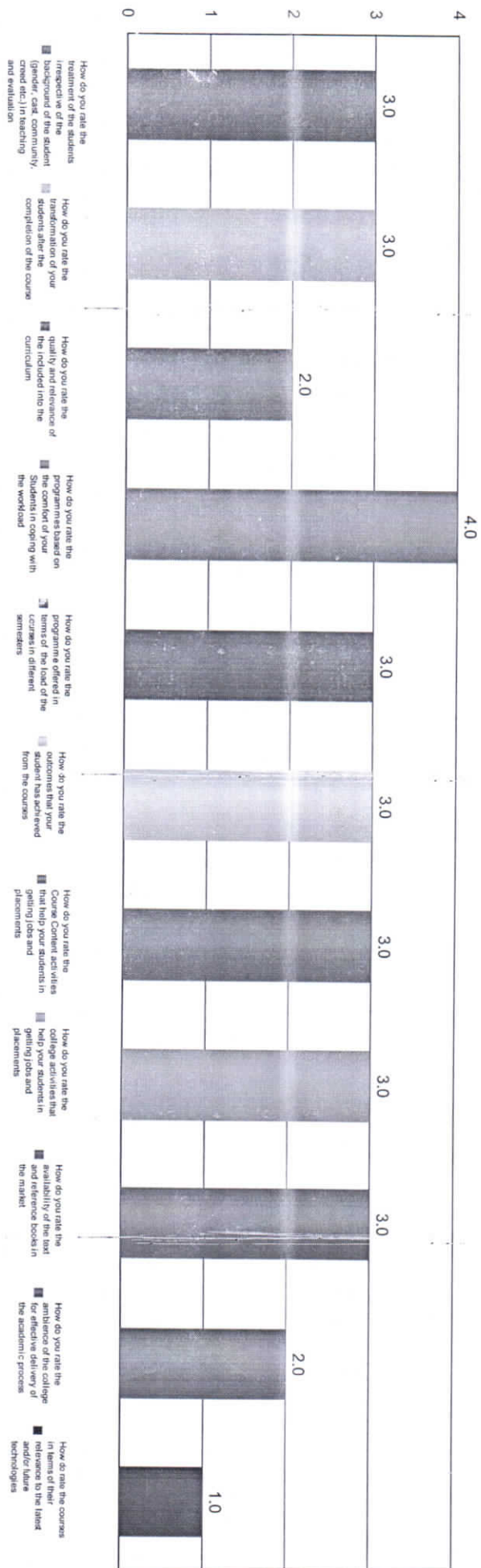

Faculty of Conservative Dentistry
and Endodontics
R.D.C.H.H. Kampur

Department	Program	How do you rate the treatment of the students irrespective of the background of the student (gender, cast, community, creed etc) in teaching and	How do you rate the transformation of your students after the completion of the course	How do you rate the quality and relevance of the included into the curriculum	How do you rate the program based on the comfort of your Students in coping with the workload	How do you rate the programme offered in terms of the load of the courses in different semesters	How do you rate the outcomes that your student has achieved from the courses	How do you rate the Course Content activities that help your students in getting jobs and placements	How do you rate the college activities that help your students in getting jobs and placements	How do you rate the availability of the text and reference books in the market	How do you rate the ambience of the college for effective delivery of the academic process	How do you rate the courses in terms of their relevance to the latest and/or future technologies
CONSERVATIVE DENTISTRY & ENDODONITICS	MASTER OF DENTAL SURGERY	3.0	3.0	2.0	4.0	3.0	3.0	3.0	3.0	3.0	2.0	1.0

Prof. & HOD
 Dept. of Conservative Dentistry
 and Endodontics
 R.D.C. M.P.C., Kanpur

Rama Dental College, Hospital & Research centre
Department of Orthodontics & Dentofacial Orthopedics

Feedback analysis (Faculty for MDS curriculum)

2021-2022

Feed back	Action taken
How do you rate the activities that help your students in getting jobs & placement. Satisfactory	Guidance will be given to prepare for various exams & job interviews.
How do you rate the availability of text and reference books in the market. Satisfactory	Recommendation will be given for including latest journals & text books in library.

JL
**Dept. of Orthodontics
Rama Dental College-Hospital
& Research Centre
A-1, Lakhapur (Near Shahu J)
Mabaraj University, Kannur-208100**



Curriculum Program Feedback Analysis [Faculty], Session : 2021-2022

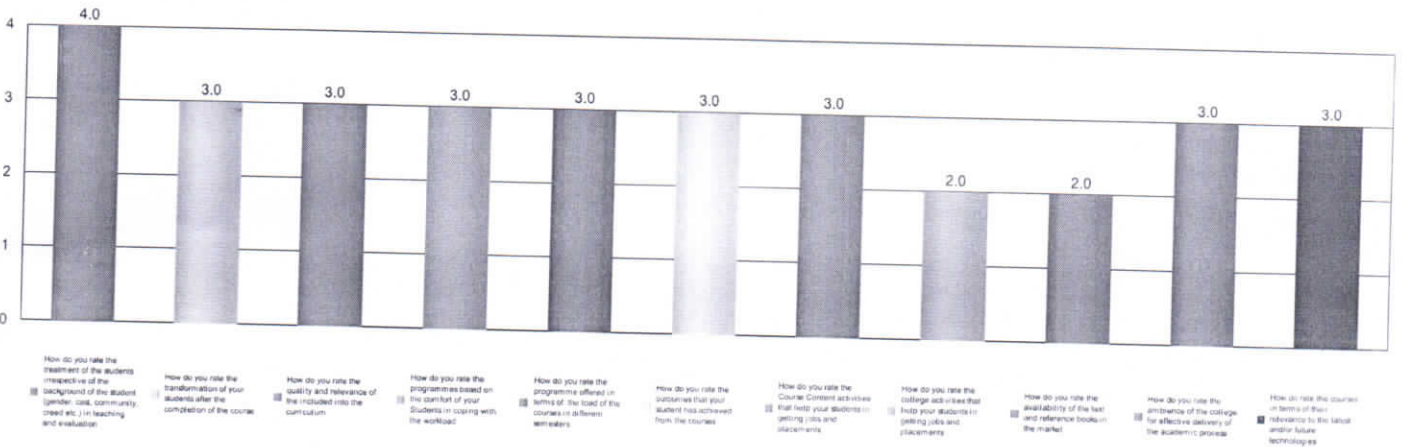

ll
**Dept. of Orthodontics
Rama Dental College-Hospital
& Research Centre
A-1, Lakhnauti, New Shahu Ji
Maharaj University, Kanpur-208002**

Department	Program	How do you rate the treatment of the students irrespective of the background of the student (gender, cast, community, creed etc.) in teaching and	How do you rate the transformation of your students after the completion of the course	How do you rate the quality and relevance of the included into the curriculum	How do you rate the programmes based on the comfort of your Students in coping with the workload	How do you rate the programme offered in terms of the load of the courses in different semesters	How do you rate the outcomes that your student has achieved from the courses	How do you rate the Co-curricular activities that help your students in getting jobs and placements	How do you rate the college activities that help your students in getting jobs and placements	How do you rate the availability of the text and reference books in the market	How do you rate the outcome of the college for effective delivery of the academic process	How do you rate the relevance of the courses in terms of their relevance to the latest and/or future technologies
ORTHODONTICS & DENTOFACIAL	MASTER OF DENTAL SURGERY	4.0	3.0	3.0	3.0	3.0	3.0	3.0	2.0	2.0	3.0	3.0

Dept. of Orthodontics
Kama Dental College-Hospital
& Research Centre
A-1, Lakhnupur (Near Shahu Ji)
Maharaj University, Kanpur-208002



RAMA UNIVERSITY UTTAR PRADESH, KANPUR

(vide U.P. Act No. 1 of 2014 as passed by State Legislature and recognized by UGC U/s 2(f))

Rama City, G.T. Road (Near Mandhana Railway Station)

Mandhana, Kanpur- 209217

Department of Oral and Maxillofacial Pathology

Rama Dental College Hospital and Research Centre Kanpur

Faculty Feedback and Action Taken Report MDS 2021-22

S No	Feedback	Action Taken
1.	How do you rate the treatment of students irrespective of the background of the student (gender, cast, community, creed etc.)	It was decided that no discrimination what so ever will be done and all will be treated as equal
2.	How do you rate the transformation of your students after the completion of the course	the students should be guided to find solutions to problems and face the issues related to practice in dentistry
3.	How do you rate the outcomes that your students has achieved from the course	The students should be guided to more carrier options and jobs related to dentistry

[Signature]
 Dept. of Oral Pathology
 & Microbiology
 Rama Dental College Hospital
 & Research Centre
 A-1, Lakhanpur (Near Shahu ji +
 Maharaj University) Kanpur-208024



Curriculum Program Feedback Analysis [Faculty], Session : 2021-2022

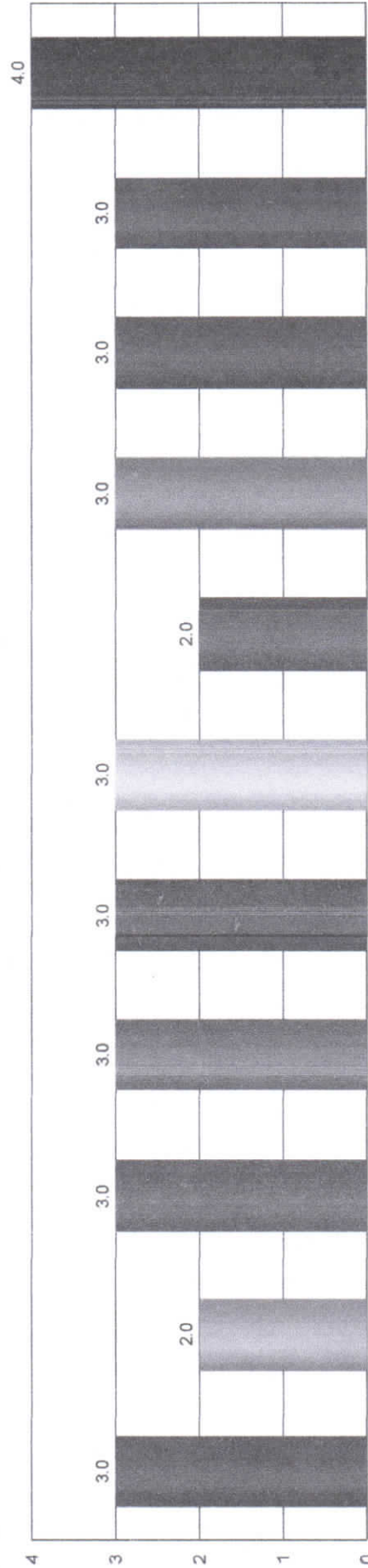

How do you rate the treatment of the students irrespective of the student background (gender, cast, community, creed etc.) in teaching and evaluation? ■

How do you rate the transformation of your students after the completion of the course? ■

How do you rate the quality and relevance of the included into the curriculum? ■

How do you rate the program based on the content of your Shalokha along with the workload? ■

How do you rate the programs offered in terms of the load of the courses in different semesters? ■

How do you rate the outcome that your student has achieved from the courses? ■

How do you rate the Course Content activities that help your students in getting jobs and placements? ■

How do you rate the college activities that help your students in getting jobs and placements? ■

How do you rate the availability of the text and reference books in the market? ■

How do you rate the aim/benefit of the college for effective delivery of the academic process? ■

How do you rate the courses in terms of their relevance to the latest and future technologies? ■

**Dept. of Oral Pathology
& Microbiology Hospital
Rama Dental College Centre
& Research Centre (Near Shahu Ji
A-1, Lakhapur (Near Shahu Ji
Maharaj University) Kanpur-208002**

Department	Program	How do you rate the treatment of the students irrespective of the background of the student (gender, cast, community, creed etc.) in teaching and	How do you rate the transformation of your students after the completion of the course	How do you rate the quality and relevance of the material included into the curriculum	How do you rate the program's based on the comfort of your students in coping with the workload	How do you rate the programme offered in terms of the load of the courses in different semesters	How do you rate the outcomes that your student has achieved from the courses	How do you rate the Course Content activities that help your students in getting jobs and placements	How do you rate the college activities that help your students in getting jobs and placements	How do you rate the availability of the text and reference books in the market	How do you rate the influence of the college for effective delivery of the academic process	How do you rate the courses in terms of their relevance to the latest and/or future technologies
ORAL PATHOLOGY & DENTAL SURGERY MICROBIOLOGI	MASTER OF	3.0	2.0	3.0	3.0	3.0	3.0	2.0	3.0	3.0	3.0	4.0

Dept. of Oral Pathology & Microbiology
Rama Dental College Hospital
& Research Centre
Near Sathu Ji
Kapur-208024
Vatara, University



RAMA DENTAL COLLEGE HOSPITAL & RESEARCH CENTRE

(Recognised by D.C.I. & Govt. of India, Accredited by NAAC)

RAMA UNIVERSITY UTTAR PRADESH

DEPARTMENT OF ORAL MEDICINE AND RADIOLOGY

FACULTY FEEDBACK AND ACTION TAKEN REPORT ON MDS CURRICULUM

(2021-2022)

S.NO	FEEDBACK	ACTION TAKEN
1.	How do you rate the college activities that help your students in getting jobs and placements	The department will be organizing CDE/Webinar/Conferences/Mock interviews and MCQ based examination so as to guide and prepare the students for job oriented examinations and interviews.
2.	How do rate the courses in terms of their relevance to the latest and/or future technologies	The department will definitely work towards the enhancement in the latest technologies at the department level which includes CBCT, Lasers etc. courses will be conducted on training the students on future advancements in dentistry at the department as well as college level.

Vishal

Dr Vishal Mehrotra

Professor & HOD, OMDR, RDC

PROFESSOR & H.O.D.
DEPT. OF ORAL MEDICINE & RADIOLOGY
RDCHRC, LAKHANPUR
KANPUR - 208024

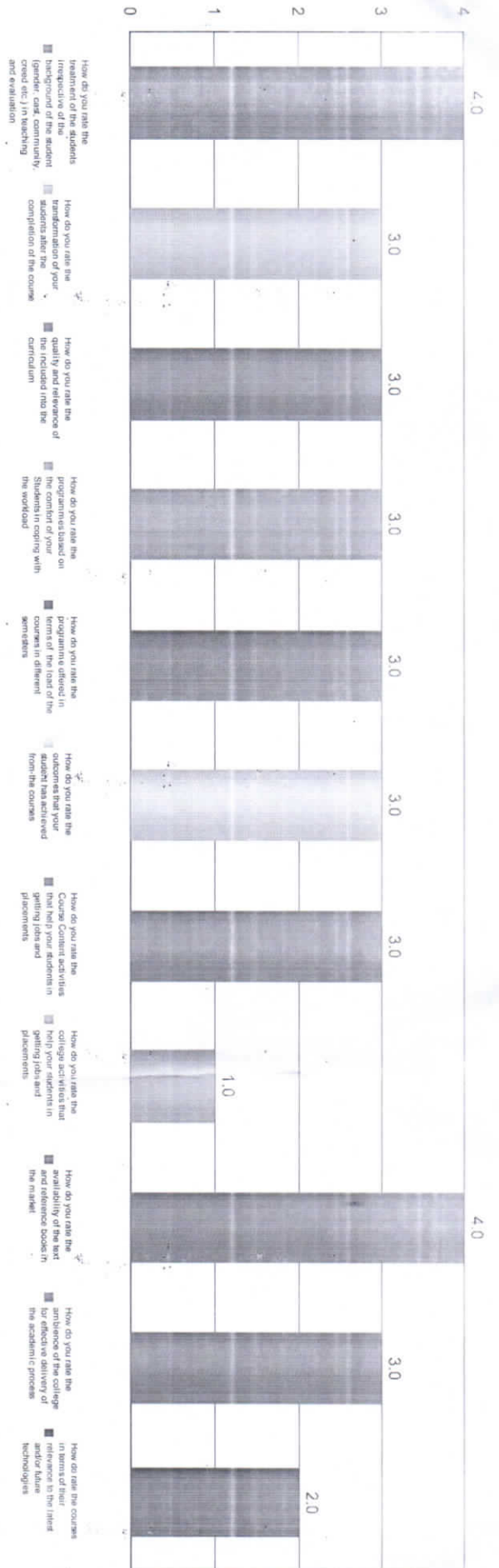

PROFESSOR & H.O.D.
 DEPT. OF ORAL MEDICINE & RADIOLOGY
 RDCHRC, LAKHANPUR
 KANPUR - 208024

Vin



RAMA DENTAL COLLEGE HOSPITAL & RESEARCH CENTRE

(Recognised by D.C.I. & Govt. of India, Accredited by NAAC)

RAMA UNIVERSITY UTTAR PRADESH

DEPARTMENT OF ORAL & MAXILLOFACIAL SURGERY

FACULTY FEEDBACK AND ACTION TAKEN REPORT ON MDS CURRICULUM

(2021-2022)

S.NO	FEEDBACK	ACTION TAKEN
1.	How do you rate the transformation of your students after the completion of the course	An overall development of the students is important. Grooming of students will be done by the faculty on both personal and professional fields
2.	How do you rate the programs based on the comfort of your Students in coping with the workload	The clinical and theoretical hours will be divided depending upon the workload of the students. Students will be monitored throughout the program to keep completing their work assigned and recognize the areas of problems in understanding the curriculum and completing their clinical workload.
3.	How do rate the college activities that help your students in getting jobs and placements	MDS staff instructed to guide students on employment at departmental level
4.	How do you rate the availability of the text and reference books in market	Faculty Pointed that many books are difficult to purchase due to unavailability or high price. This disturbs the studies of the students hence MDS staff instructed to share soft copies of such books

Dr. Prasanna Kumar P

Head of department

Department of Oral & Maxillofacial Surgery

Dr. PRASANNA KUMAR P MDS
Prof. & HEAD OF DEPARTMENT
ORAL & MAXILLO FACIAL SURGERY
RAMA DENTAL COLLEGE, HOSPITAL &
RESEARCH CENTRE, KANPUR (UP)



Curriculum Program Feedback Analysis [Faculty], Session : 2021-2022

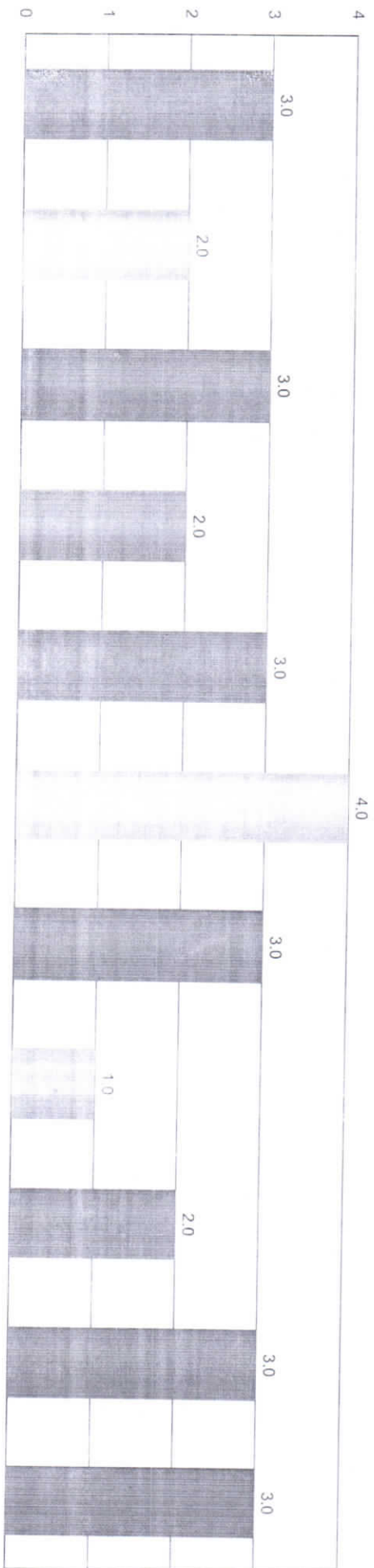

[Signature]
Dr. PRASANNA K. TIMAR P MDS
Prof. & HEAD OF DEPARTMENT
ORAL & MAXILLO FACIAL SURGERY
RAMA DENTAL COLLEGE, HOSPITAL &
RESEARCH CENTRE, KANPUR (UP)

Department	Program	How do you rate the treatment of the students (respectively of the background of the student (gender, social community, creed etc.) in teaching and	How do you rate the transformation of your students after the completion of the courses	How do you rate the quality and relevance of the method of your teaching activities	How do you rate the programs based on the content of your Students in coping with the workload	How do you rate the programs offered in terms of the level of the courses to address students	How do you rate the outcomes that your student has achieved from the courses	How do you rate the course content activities that help your students in getting jobs and placements	How do you rate the college activities that help your students in getting jobs and placements	How do you rate the availability of the text and reference books in the market	How do you rate the ambience of the college for effective delivery of the academic process	How do you rate the course in terms of their relevance to the latest and/or future technologies
ORAL AND MAXILLOFACIAL SURGERY	MSSTRORF	3.0	2.0	3.0	2.0	3.0	4.0	3.0	1.0	2.0	1.0	3.0

DR. PRASANNA KUMAR P.M.S
Prof & HEAD OF DEPARTMENT
ORAL & MAXILLO FACIAL SURGERY
RESEARCH CENTRE, KANPUR (UP)
RAJA DENTAL COLLEGE HOSPITAL &



RAMA DENTAL COLLEGE HOSPITAL & RESEARCH CENTRE

(Recognised by D.C.I. & Govt. of India, Accredited by NAAC)

RAMA UNIVERSITY UTTAR PRADESH

2

de

Department of Prosthodontics Crown & Bridge MDS curriculum feedback analysis and action-taken report



Curriculum Program Feedback Analysis [Faculty], Session : 2021-2022

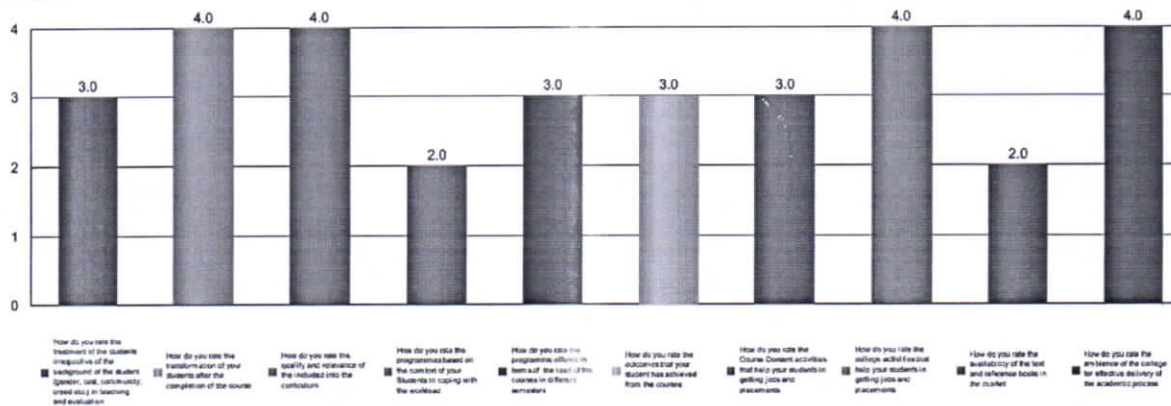

Feedback (2021-2022)

Feedback	Action-taken report
a. How do you rate the programmes based on the comfort of the students in coping with the workload	Students are expected to cope with the curriculum workload and the staff would be instructed to ease the pressure on the students by segmenting the academic activities on priority basis and complete the same on periodic basis.
b. How do you rate the availability of text and reference books in the market	Reference text books not available is a major issue that could be tackled by using online resources like e-text books and online articles.

Gai
Head of Department
Department of Prosthodontics
Rama Dental College
Hospital & Research Centre, Kanpur



RAMA DENTAL COLLEGE HOSPITAL & RESEARCH CENTRE

(Recognised by D.C.I. & Govt. of India, Accredited by NAAC)

RAMA UNIVERSITY UTTAR PRADESH

DEPARTMENT OF PERIODONTOLOGY

FACULTY FEEDBACK ANALYSIS AND ACTION TAKEN REPORT ON MDS CURRICULUM – 2021-22

S.NO	FEEDBACK	ACTION TAKEN
1.	How do you rate the transformation of your students after the completion of the course	Evaluation is done by conduction of periodic theory and practical examinations, presentation of seminars, journal clubs, case presentation etc.
2.	How do you rate the course content activities that help you students in getting jobs and placements	The dental courses are divided into theory and clinical classes for better understanding of the subject. As dentistry is more of a clinical orientation, job emphasis is made to provide students with more of clinical exposures by increasing their practical hours and camp/field visits etc.
3.	How do you rate the course in terms of their relevance to the latest and/or future technologies	Relevant advanced instruments and methods were included in their training course.

Dr Janardhana Amaranath BJ

HOD, Dept of Periodontology

Deptt. of Periodontology
Rama Dental College, Kanpur

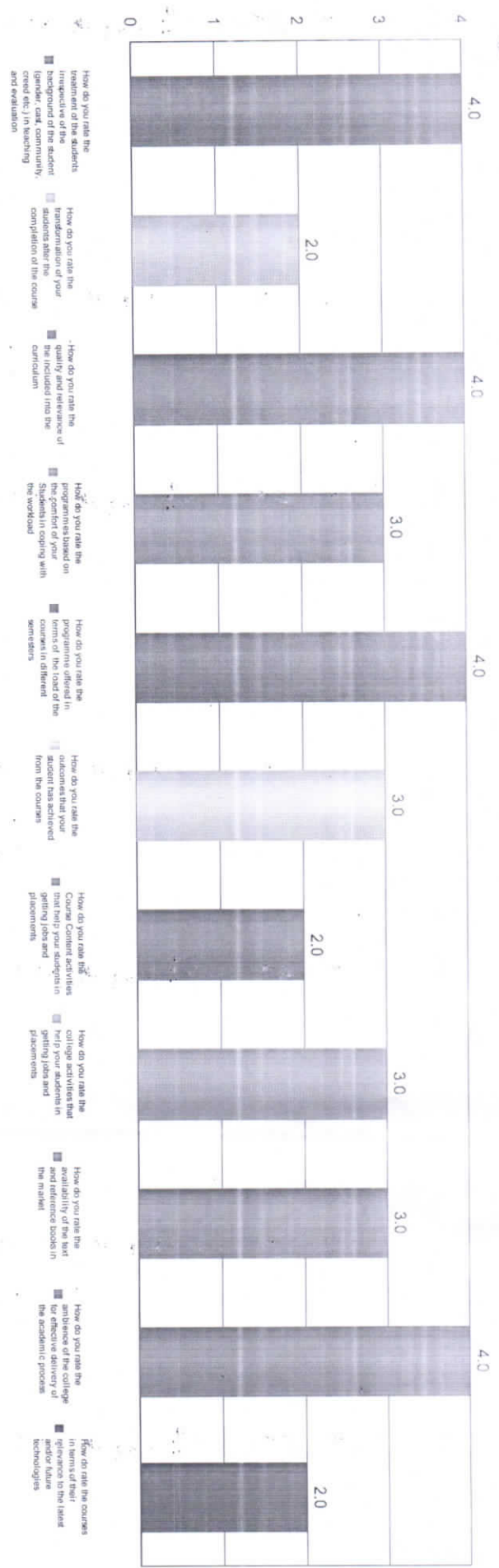

H.O.D.
 Dept. of Periodontology
 Rama Dental College, Kanpur

[Handwritten signature]

Dept. of Periodontology
Rang Dental College, Kanpur

H.O.D.
[Signature]

PERIODONTOL OCY	Department	Program	How do you rate the preparation of the students irrespective of the background of the student (gender, cast, community, etc.) w.r.t. teaching and	4.0	How do you rate the transferability of your students after the completion of the course	2.0	How do you rate the quality and relevance of the included lab the curriculum	4.0	How do you rate the preparations based on the exhibit of your students in employ with the workload	3.0	How do you rate the preparation offered in terms of the load of the students in different semesters	4.0	How do you rate the experiences that your student has achieved from the course	3.0	How do you rate the course content activities that help your students in getting jobs and placements	2.0	How do you rate the range activities that help your students in getting jobs and placements	3.0	How do you rate the availability of the relevant reference books in the market	3.0	How do you rate the ambience of the college for effective delivery of the academic process	4.0	How do you rate the use of their reference to the latest academic technologies	2.0
--------------------	------------	---------	--	-----	--	-----	---	-----	---	-----	---	-----	---	-----	--	-----	--	-----	---	-----	---	-----	---	-----



Rama Dental College Hospital & Research Centre

Department of Public health Dentistry

Faculty Feedback & Action Taken Report on MDS Curriculum

Batch 2021-22

S.no	Feedback	Action taken
1.	How do you rate the quality and relevance of the included into the curriculum	More outreach activities and clinical exposure are planned for the students
2.	How do you rate the ambience of the college for effective delivery of the academic process	Upgradation of mobile dental van is being planned and Access to Digital departmental library will be provided.
3.	How do you rate the programmes based on the comfort of your Students in coping with the workload	Even distribution of the work per year is planned
4.	How do you rate the college activities that help your students in getting jobs and placements	More career options in India and abroad will be researched and suggested

H.O.D

Department of Public Health Dentistry

Professor & Head
Dept. of Public Health Dentistry
Rama Dental College Hospital, Kanpur



Curriculum Program Feedback Analysis [Faculty], Session : 2021-2022

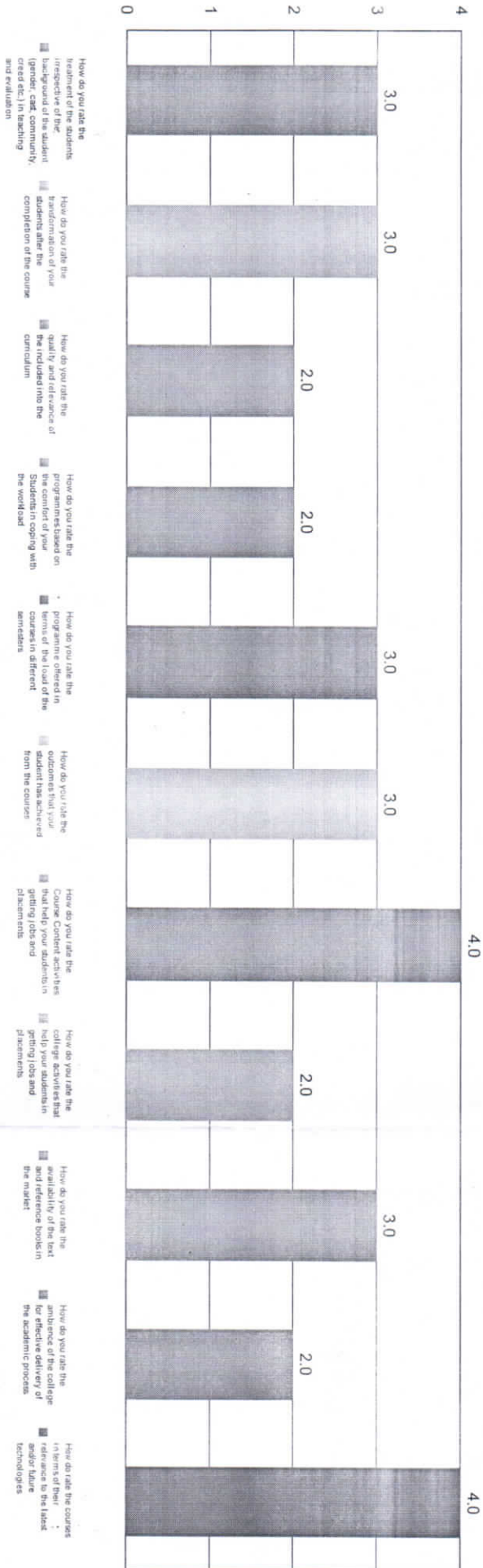

Professor & Head
 Dept. of Public Health Dentistry
 Raina Dental College & Hospital, Kanpur

Department	Program	How do you rate the treatment of the students (respectively of the background of the student (gender, cast, community, creed etc.) in teaching and	How do you rate the transformation of your students after the completion of the course	How do you rate the quality and relevance of the included into the curriculum	How do you rate the performance based on the standard of your students in coping with the workload	How do you rate the programme offered in terms of the load of the courses in different semesters	How do you rate the outcome that your student has achieved from the courses	How do you rate the Course Content activities that help your students in getting jobs and placements	How do you rate the activities that help your students in getting jobs and placements	How do you rate the availability of the text and reference books in the market	How do you rate the ambience of the college for effective delivery of the academic process	How do you rate the courses in terms of their relevance to the latest and/or future technologies
PUBLIC HEALTH DENTISTRY	MASTER OF DENTAL SURGERY	3.0	3.0	2.0	2.0	3.0	3.0	4.0	2.0	3.0	2.0	4.0

 Professor & Head
 Dept. of Public Health Dentistry
 Rama Dental College & Hospital, Kanpur

RAMA DENTAL COLLEGE, HOSPITAL AND RESEARCH CENTRE
DEPARTMENT OF PEDIATRIC AND PREVENTIVE DENTISTRY

Faculty Feedback analysis for MDS Curriculum
(2021-2022)

FEEDBACK	ACTION TAKEN
Rate the course content activities that help your students in getting jobs and placements- satisfactory	We will be training the students to acquire knowledge and skills to face the various interviews for the jobs.
Rate the college activities that help your students in getting jobs and placements- satisfactory	We will guide them regarding books and journals to prepare themselves for the interviews and written tests.

Arun Sharma

Dr Arun Sharma
Prof. & HOD

Dept. of Pedodontics
rama Dental College-Hospital
& Research Centre
V-1, Lakhnao Shahu ji
Jhansi, U.P. Pin-208002



Curriculum Program Feedback Analysis [Faculty], Session : 2021-2022

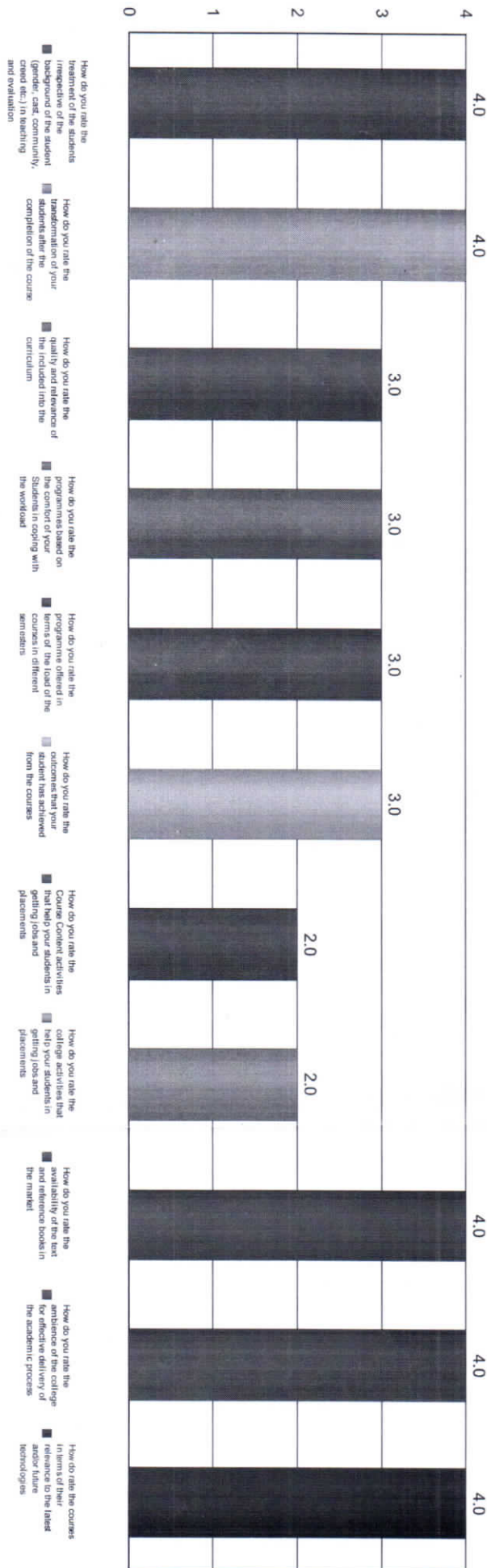

Dr. Anand K. J.

 Dept. of Pedodontics

 Rama Dental College-Hosur

 & Research Centre

 A-1, Lakshnapuram

 MaharaJ University, Hosur

Department	Program	How do you rate the treatment of the students irrespective of the background of the student (gender, cast, community, creed etc.) in teaching and	How do you rate the transformation of your students after the completion of the course	How do you rate the quality and relevance of the included into the curriculum	How do you rate the programs based on the comfort of your Students in coping with the workload	How do you rate the programme offered in terms of the load of the courses in different semesters	How do you rate the outcomes that your student has achieved from the courses	How do you rate the Course Content activities that help your students in getting jobs and placements	How do you rate the college activities that help your students in getting job and placements	How do you rate the availability of the text and reference books in the market	How do you rate the ambience of the college for effective delivery of the academic process	How do you rate the courses in terms of their relevance to the latest and/or future technologies
PEDIATRIC AND PREVENTIVE DENTISTRY	MASTER OF DENTAL SURGERY	4.0	4.0	3.0	3.0	3.0	3.0	2.0	2.0	4.0	4.0	4.0

Keleware

Dept. of Pedodontics
Kama Dental College-Hospital
& Research Centre
A-1, Lakshampur, Near Shahu ji
Mebaraj University, Kavaratti-596102